

Cemetery General Information Package



Please see our full Cemetery Policies, Procedures and Information Manual for more details

Most forms, permits and documents are available to download in pdf format from our website or contact The Parks & Cemetery Coordinator for assistance.

Town of Canmore Public Works
Parks & Cemetery Department
Phone: 403.678.1599
E-Mail: cemetery@canmore.ca
Web Site: www.canmore.ca

CEMETERY LOCATION

The Canmore Cemetery (+) is located just off Palliser Trail (map on page 6).

The Cemetery includes plots available for in ground interments and a Columbarium for cremated remains.



There are two Field of Honour sections.
Each section has a memorial or a cenotaph.

A Columbarium was installed in 2008. It is an above ground granite structure which allows for the placement of cremated remains in a niche. Each niche is capable of holding two urns.



The Cemetery includes an old historic section that dates back to the early 1800's.

VISITING HOURS

We are open to the public daily from 8:00 am to 8:00 pm.

The main gates are sometimes locked allowing only foot traffic. There is a small parking lot located just outside the gates and a larger parking lot at the bottom of the hill before the cemetery. For interment services, the main gates will be opened.

An information kiosk is located opposite the Columbarium. You can also visit our website should you wish to look up the location of a loved one.

CEMETERY LOCATION MAP

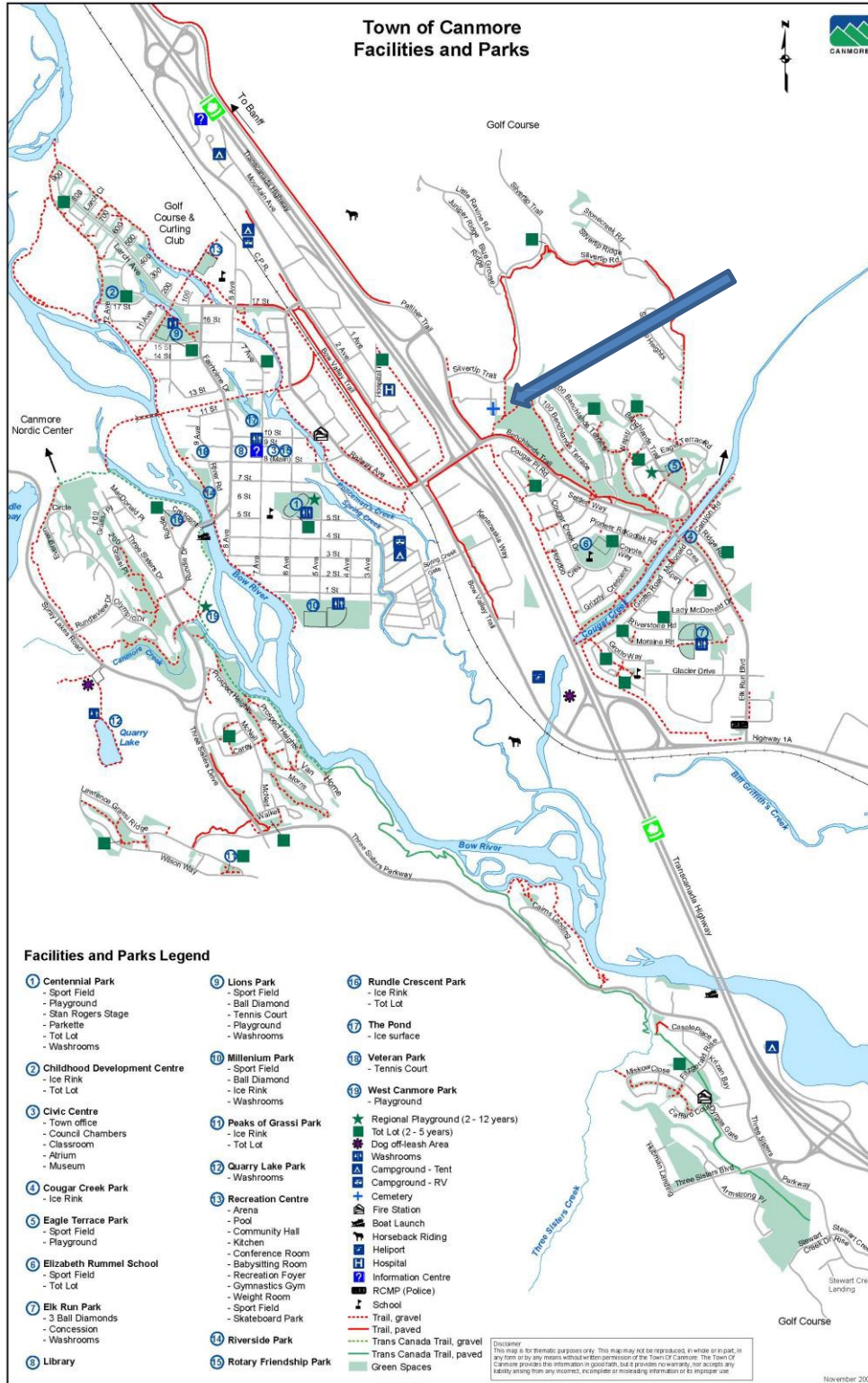

Canmore Cemetery Sections

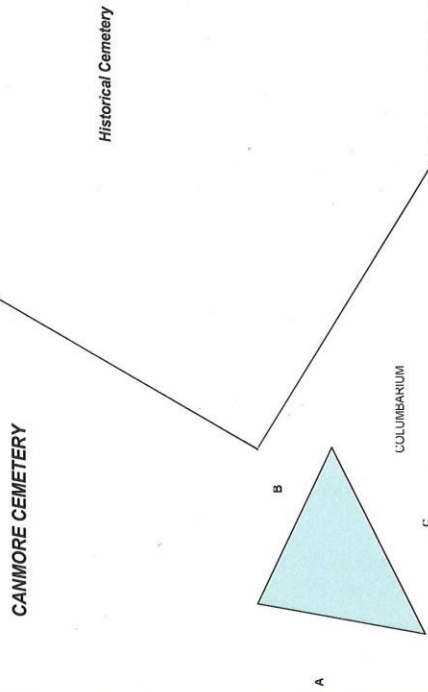

| West Section G | | | | West Section H | | | | West Section A | | | | West Section B | | | | | | | | | | | | | | | | | | | | | | | | | | | | | | | | | | | | | | | | | | | | | | | | | | | | | | | | | | | | | | | | | | | | | | | | | | | | | | | | | | | | | | | | | | | | | | | | | | | | | | | | | | | | | | | |
|----------------|-----|-----|-----|----------------|-----|-----|-----|----------------|-----|-----|-----|----------------|-----|-----|-----|----------------|-----|-----|-----|----------------|-----|-----|-----|----------------|-----|-----|-----|----------------|-----|-----|-----|-----|-----|-----|-----|-----|-----|-----|-----|-----|-----|-----|-----|-----|-----|-----|-----|-----|-----|-----|-----|-----|-----|-----|-----|-----|-----|-----|-----|-----|-----|-----|-----|-----|-----|-----|-----|-----|-----|-----|-----|-----|-----|-----|-----|-----|-----|-----|-----|-----|-----|-----|-----|-----|-----|-----|-----|-----|-----|-----|-----|-----|-----|-----|-----|-----|-----|-----|-----|-----|-----|-----|-----|-----|-----|-----|-----|-----|-----|-----|-----|-----|-----|-----|-----|-----|-----|-----|-----|-----|-----|-----|------|
| 877 | 878 | 879 | 880 | 881 | 882 | 883 | 884 | 885 | 886 | 887 | 888 | 889 | 890 | 891 | 892 | 893 | 894 | 895 | 896 | 897 | 898 | 899 | 900 | 901 | 902 | 903 | 904 | 905 | 906 | 907 | 908 | 909 | 910 | 911 | 912 | 913 | 914 | 915 | 916 | 917 | 918 | 919 | 920 | 921 | 922 | 923 | 924 | 925 | 926 | 927 | 928 | 929 | 930 | 931 | 932 | 933 | 934 | 935 | 936 | 937 | 938 | 939 | 940 | 941 | 942 | 943 | 944 | 945 | 946 | 947 | 948 | 949 | 950 | 951 | 952 | 953 | 954 | 955 | 956 | 957 | 958 | 959 | 960 | 961 | 962 | 963 | 964 | 965 | 966 | 967 | 968 | 969 | 970 | 971 | 972 | 973 | 974 | 975 | 976 | 977 | 978 | 979 | 980 | 981 | 982 | 983 | 984 | 985 | 986 | 987 | 988 | 989 | 990 | 991 | 992 | 993 | 994 | 995 | 996 | 997 | 998 | 999 | 1000 |
| West Section I | | | | West Section J | | | | West Section K | | | | West Section L | | | | West Section M | | | | West Section N | | | | West Section O | | | | | | | | | | | | | | | | | | | | | | | | | | | | | | | | | | | | | | | | | | | | | | | | | | | | | | | | | | | | | | | | | | | | | | | | | | | | | | | | | | | | | | | | | | | | | | | | | | | |
| West Section G | | | | West Section H | | | | West Section A | | | | West Section B | | | | West Section C | | | | West Section D | | | | West Section E | | | | West Section F | | | | | | | | | | | | | | | | | | | | | | | | | | | | | | | | | | | | | | | | | | | | | | | | | | | | | | | | | | | | | | | | | | | | | | | | | | | | | | | | | | | | | | | | | | | | | | | |

Entrance

PURCHASING A PLOT/NICHE

The Town offers the sale of plots (in ground burials) and niches in a Columbarium to both Residents and Non Residents.

When you purchase a plot or a niche, you will receive a 'Certificate of Easement' (Interment Rights) paper. At the time of sale, you will have to sign a 'Right to Cancel by Purchaser' form.

Our current fees are located in our Fee section of this manual

General Certificate of Easement Information:

- A sale of a plot or a niche can be viewed as a long term lease. The land ownership is retained by the Cemetery owner (Town of Canmore) and the right of interment is purchased with a sale.
- The legal owner has the only authority over the authorizations of interments and memorials for the interment location.
- The Town hereby agrees to maintain and perpetually care for the said grave plot in the Canmore Cemetery of the Town of Canmore.
- Maintenance and perpetual care shall connote and include the filling and reseeded of any sinking grave on the said plot, and generally perform all things necessary and expedient to preserve the said grave plot in a healthy, neat and tidy condition and to properly care for and protect the same as far as the funds available thereunto will extend.
- The owner must contact the Town if they have a change of personal information (change of legal name or address).
- The plot/niche must be used within 20 years. If it is not used, the owner must contact the Town and request a 10 year extension.
- If the owner of a vacant plot is deceased, the beneficiary must contact the Town and request a Transfer of Ownership. We will request Proof of Inheritance documentation at the time of the transfer request.
- The Town shall have the right to refuse to sell more than 4 (four) single plots or niches to any one individual or estate.

Cancellation / Refund Policy:

- As per the *Alberta Cemeteries Act*, cancellation of a contract can be requested at any time for any reason.
- The purchaser/owner may cancel without charge or penalty at any time during the period from the day he/she enters into the contract until 30 days after he/she receives a copy of the contract.
- If the purchaser/owner cancels after 30 days he/she may still have to pay for interment space and for any cemetery supplies and cemetery services that have already been supplied, performed or delivered, as the case may be.

- To cancel, the purchaser/owner must give a notice of cancellation to the owner of the cemetery as outlined in the Certificate of Easement.
- The purchaser/owner should give notice of cancellation by a method that will allow him to prove that he gave notice, such as registered mail, fax, and courier or by personal delivery.

Resale of Interment Space:

- After the penalty free 30-day cancellation period is over, the Town will not allow the purchaser/owner to resell his/her interment space on the open market. The owner can sell the **unused** interment space back to the Town of Canmore who must pay him/her at least 85% of its market value at the date of resale.
- To cancel, the purchaser/owner must give a notice of cancellation to the owner of the cemetery.
- The purchaser/owner should give notice of cancellation by a method that will allow him/her to prove that he/her gave notice, such as registered mail, fax, and courier or by personal delivery.

BURIAL (INTERMENT) OPTIONS

Plot (Earth Burial) Interment Options

The *Canmore Cemetery Bylaw* has criteria for the interment of human remains, including standards for depth of burial and size of casket or grave liner per each 3'.5" x 10' plot. The following are minimum standards, and it is recommended that our office be contacted for additional details concerning grave and cremation burials.

- A single interment (casket) in a single plot is 3'.5" x 10'.
- A double interment (casket) in a double plot (which is 2 single plots) side by side has a combined size of 7' x 10'.
- There are no double depth casket burials permitted in the Canmore Cemetery.
- Multiple interments to a maximum of 4 (four) interments of cremated remains in a pre-occupied (casket) single plot **(see Figure 1)**.
- Multiple interments to a maximum of 8* (eight) interments of cremated remains in a single plot solely for cremated interments **(see Figure 2)**.
- A single interment (casket) in a single plot which is 3'.5" x 10' in the Field of Honour.
- The interment of the cremated remains of a spouse with a pre deceased veteran in the Field of Honour.

* Plots with interred cremated remains prior to 1996 may only permit up to a maximum of 4 (four) interments of cremated remains. This is due to the fact that prior to the Cemetery Bylaw in 1996, urn interments were only placed at a 2' depth, therefore not allowing a total of 8 urns to fit in these plots.

Single Plot Casket/Urn Burial Combination

(Figure 1)

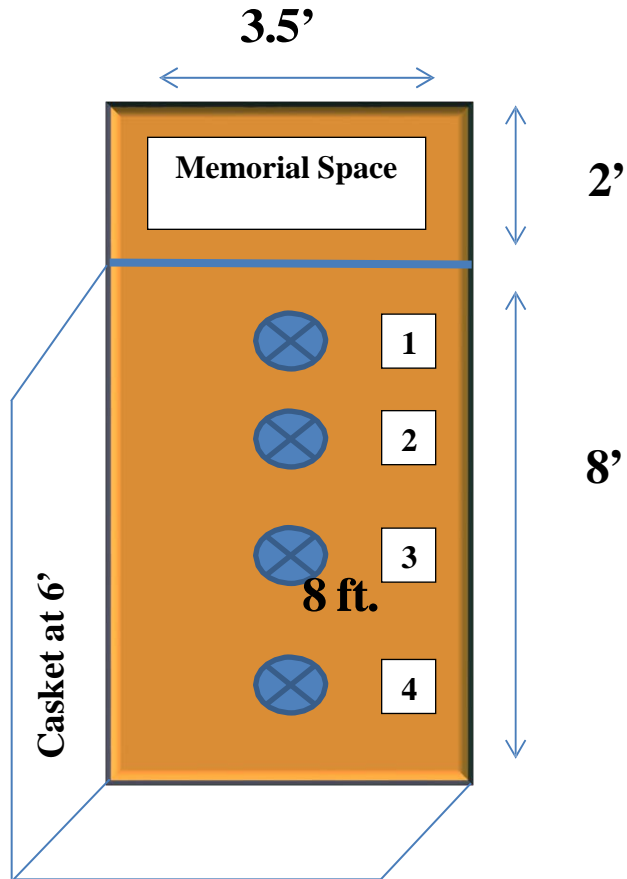

A single casket must go first, then up to

4 urns at a 2' depth 

Single Plot Burial- Urns Only

(Figure 2)

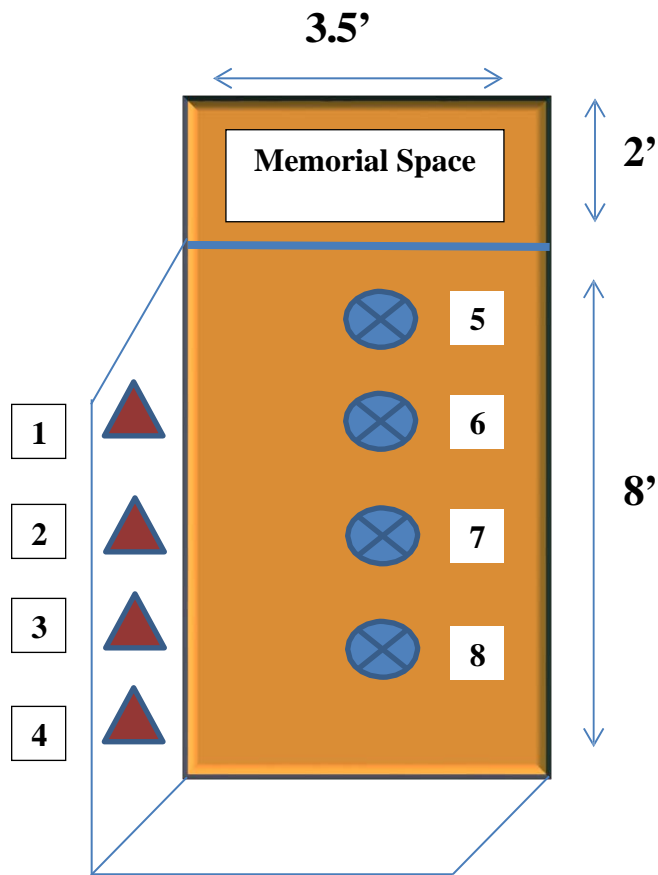

*up to 8 urns

First layer up to 4 urns  positions 1-4 on diagram at a 4' depth

Second layer up to 4 urns  positions 5-8 on diagram at a 2' depth

Concrete Burial Liners (or grave liners)

- It is a mandatory requirement on all regular casket interments that concrete burial liners (or grave liners) are used.
- All casket burial must be arranged through a Funeral Company. Arrangements to purchase a grave liner must be made with the Funeral Company that is administering the interment.

Field of Honour

The *Alberta Cemetery Act* and the *Canmore Cemetery Bylaw* have the following criteria for the interment of veterans and their spouses:

- A single interment (casket) in a single plot in the Field of Honour section.
- The interment of the cremated remains of a spouse with a pre deceased veteran in the Field of Honour section.
- The *Canmore Royal Canadian Legion - Three Sisters Branch* must provide written approval to the Town to allow a veteran to be interred in the Field of Honour.
- There is no charge for the plot but there are interment fee charges. Invoicing details must be included on the interment application form.

Urn Interment Option - Columbarium



The Columbarium has 3 walls with 60 niche units on each wall. Each niche is sold as one unit.

Each niche is capable of holding two urns of a limited size. The inside diameter of the niche is just slightly smaller than 12" high x 12" wide X 16" deep.



When you purchase a niche in the Columbarium, it includes the black granite door covering the niche. The door may be engraved at additional cost to the customer. The granite door may not be engraved until there has been an interment or arrangement for an interment made.

CANMORE COLUMBARIUM
Wall Sections A/ B/ C

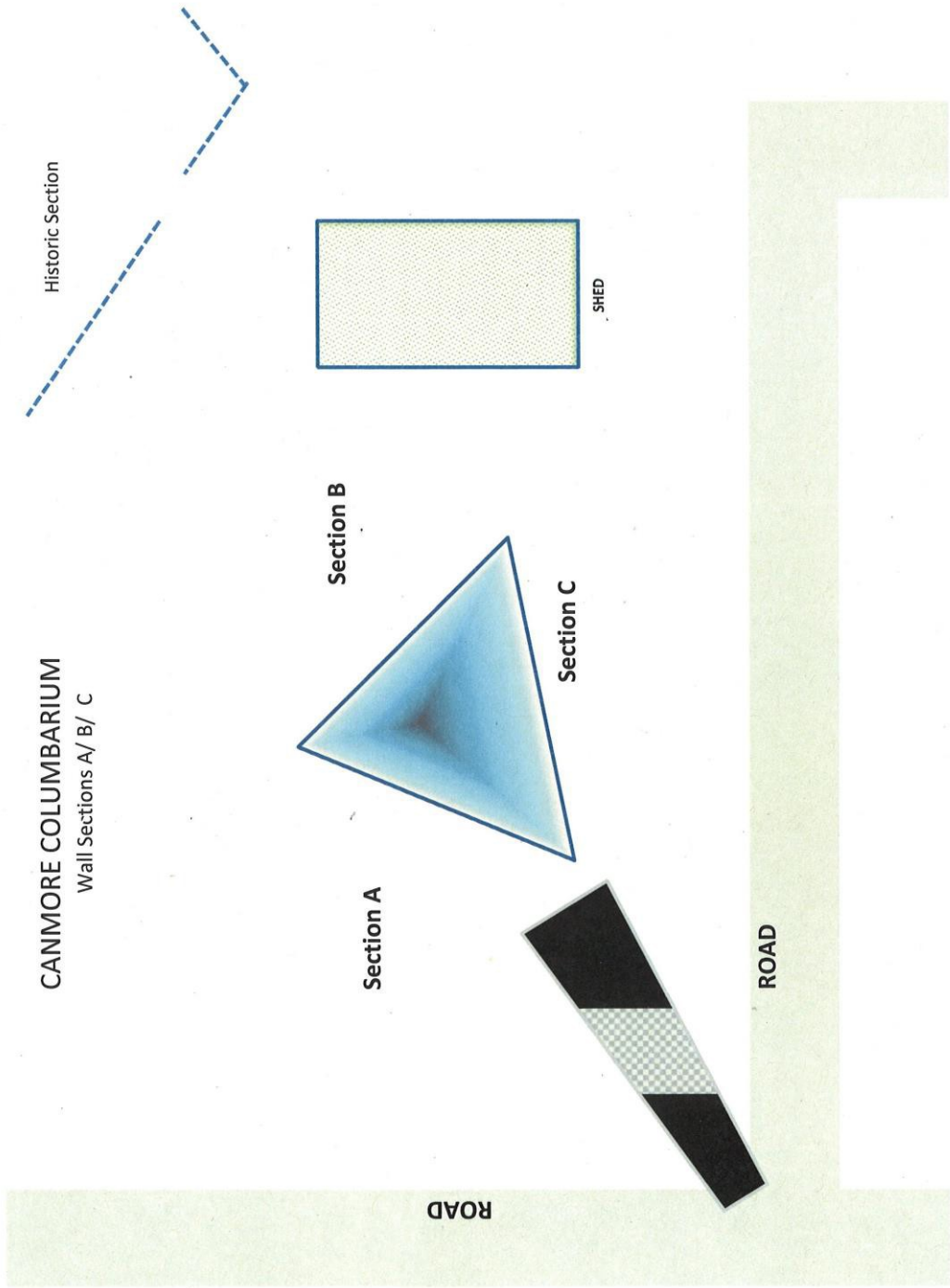

PLANNING AN INTERMENT (BURIAL)

General Interment Regulations:

- No interment shall be permitted without a proper interment application form submitted by the party applying for the interment.
- All casket burial must be arranged through a Funeral Company and they can assist with filling in an interment application form. Arrangements to purchase a grave liner must be made with the Funeral Company that is administering the interment.
- The legal owner of a plot or niche has the only authority over the authorization for interments and memorials being requested for the interment location. In the event that the legal owner on record is deceased, their legal representative and or the executor / executrix must be identified.
- For all casket burials, no interment shall take place in the Cemetery unless the Funeral Director, plot owner or their legal representative has delivered an original burial permit to our office.
- For all cremation burials (in ground or niche), no interment shall take place in the Cemetery unless the Funeral Director, plot owner or their legal representative has at least provided a copy of either a burial permit or a cremation certificate to our office.
- In the event the owner is deceased and there is no executor or legal representative identified then refer to the *Alberta Cemetery Act - General Regulation* Section 11 which states:

Alberta Cemetery Act- Who may control disposition:

Where the owner of a cemetery, crematory or mausoleum or a columbarium operator is faced with a dispute among a deceased's family or others concerning who has the right to control the disposition of the deceased's remains, the owner of the cemetery, crematory or mausoleum or a columbarium operator shall, subject to the order of a court, recognize a person's right to control the disposition of those remains in the following order of priority (first four only shown below):

- 1. Estate trustee, also called an executor or executrix, who is named in the deceased person's will (or an administrator appointed by the court through a Letter of Probate, Letter of Administration or a Court Order)*
- 2. Spouse or adult interdependent partner of the deceased*
- 3. Adult children*
- 4. Parents of the deceased*

Applying for an Interment:

- Start by filling in an interment application form and call our office about booking a date to do an interment. Our staff will assist you with understanding the regulations and help you with filling in the necessary permits and forms required.
- All permit applications for interments shall be made during regular business hours and, if the plot is owned, then no less than 48 (forty-eight) business hours prior to the interment. In the case of frost conditions, 72 (seventy-two) business hours are needed. If the purchase of a plot is required first, then additional time will be required.
- After you or the Funeral Company have spoken with us, fax the completed interment application form to our office at (403) 678-1586 or scan and send via e-mail.
- The Funeral Company shall have all applications for interments confirmed by the owner of the plot or by the legal representative of the owner.
- It is a mandatory requirement on all regular casket interments that concrete burial liners (or grave liners) are used. The Funeral Company must make arrangements with a vault company to provide this. The Funeral Company must ensure they state on the interment application form when the vault company will arrive at the Cemetery.
- For all casket burials we must have an original burial permit sent to the office before the interment can take place.
- For all cremation burials (in ground or niche), we require a faxed or scanned copy of either a burial permit or a cremation certificate.
- Interment application forms are available on our web site. Interment fees are located in the Fee section of this manual.

INTERMENT SERVICE INFORMATION

Pall Bearing Services

Town employees are not permitted nor expected to provide pall bearing services. For traditional casket burials, it is expected that you have made arrangements with the Funeral Company, family or friends to provide pallbearers for the cemetery service.

Lowering of Urn into a Grave Site- 4' depth

The Town will upon request provide a small shovel which may be used to lower most urns into the interment space.

The Town will upon request provide a small shovel and pale of earth for any in ground interment service.

Closure of Ground Grave Site

It is mandatory that the Cemetery grounds be fully vacated by the funeral party before our staff will proceed with the closure of all ground burials.

Closure of Columbarium Niche

For any interment in the Columbarium, the niche cover is removed for the service allowing the family to place the urn in the niche.

When your service is complete, we request that the funeral party vacates the immediate area around the Columbarium. Our staff will then close the niche and place the granite door on the unit.

If the ending of your service is within a ½ hour of our main gate closure time of 4:30 pm we ask the funeral party to fully vacate all vehicles from the Cemetery grounds. Our staff will then close the niche as well as lock the main gates. The Cemetery will still be accessible through walk in for visiting or to return to viewing the Columbarium.

Weekend and Statutory Holiday Labour Fees

Interment services held on a Saturday/ Sunday or a Statutory Holiday are subject to Weekend and Statutory Holiday Labour Fees (in addition to interment fees for each burial type).

Late Labour Fees Weekday, Weekend and Statutory Holiday

Interment services that have not completed their graveside service at the Cemetery by 3:30 pm could be subject to late labour fees.

Late labour fees are calculated per hour per labourer and begin after 4:30 pm.

ADORNMENT

General Provisions and Guidelines

Plots may not be adorned except for monuments as permitted and outlined in these regulations:

- Flowers (natural or artificial) may be placed on or near the monument at any time.
- Flowers that become unsightly overtime will be removed and discarded.
- Flowers are subject to environmental factors beyond our control. The Town assumes no responsibility for loss or damage to floral tributes placed on graves.
- Environmental and/or site conditions may alter the placement of a flower arrangement. Flowers found in the grounds and not matched to a grave site will be removed and discarded.
- The Town does not permit the planting of trees, shrubs or flowerbeds in the Cemetery.

- The Town may remove or prohibit the placing of any stand, holder, vase or other receptacle for flowers; any plant plots, jars, bottles, iron or wire work; any ornaments, which the Town deems unsuitable for the Cemetery.

Columbarium Adornment

- The Town may remove or prohibit the placing of mementoes, flowers or any other items on the Columbarium or niche covers except for flowers in the attached niche vase holders.
- Items affixed to the outside of the niche or left on the ground will be removed without notice. Any damages caused to the niche front due to prohibited materials will be the financial responsibility of the owner.

MEMORIALS

General Memorial Regulations

- Memorials shall cover monuments, memorial tablets and niche covers.
- Permits are required for all memorial installations/ inscriptions/ cleaning. Only Monument Companies are allowed to do memorial work.
- Permits must be applied before manufacturing to insure the memorial request meets the *Canmore Cemetery Bylaw* regulations.
- Permit work for memorials may only take place from Monday to Friday from 8:00 am to 4:00 pm.
- Permit work for memorials typically can only take place between April and October, weather and frost conditions permitting.
- Niche Erecting or Niche Removal permits are accepted year round.
- Memorials may not be installed prior to an interment except on a double plot where a marker is installed, which provides for the memorialization of 2 (two) persons where 1 (one) has predeceased the other and has been interred.
- Not more than one monument or memorial tablet shall be placed at the head of a plot regardless of its size.
- The length measurement of a monument, memorial tablet or foundation shall mean the measurement as it would face the lot measure from left to right; the width shall mean the measurement as it would face the lot measured from the head of the lot to the foot of the lot; the depth (or thickness) shall mean the height from top to bottom.
- When a plot is purchased for the intent to accommodate 8 (eight) cremated interments or 4 (four) cremated interments in a pre-occupied plot (casket) the owner is permitted 4 (four) memorial tablets placed over the cremated interments. This is in addition to an existing monument or memorial tablet at the head of the plot. The memorial tablet for this application shall be 20" length x 12" width x 4" depth.

- The owner is responsible for the proper condition and replacement of a monument and the Town assumes no liability or responsibility for loss or damage to any monument through acts of vandalism or natural erosion.
- The Town may remove a damaged monument.
- Permit forms, including fees, are available on our website. Permit fees are located in our Fee section of this manual.

Permit Requirements

The following regulations address the general monument application process. Please contact our office for further specifications and exceptions:

Permit types include:

- Monument Erecting Permit (MEP)** is for all new monuments and tablets.
- Niche Erecting Permit (NCE)** is for engraving the niche door.
- Monument Removal or Engraving Permit (MR)** is for work to an existing monument or tablet such as; removal for cleaning, repair inscriptions; remove and replace existing monument, on site engraving.
- Niche Removal Permit (NCR)** is for work to an existing pre engraved niche door such as additional inscription, cleaning, repair and maintenance.

Permit Process:

1. The Monument Company meets with the client to obtain their requested information
2. The Monument Company completes the appropriate permit and contacts the Town if additional information is required
3. The Monument Company faxes the permit request to the Town. All permits must be signed by the Monument Company
4. The Town will review the permit request and determine whether all requirements are met
5. If the permit is complete, administration will fax it back with an approved signature. If it is incomplete, they will contact the Monument Company
6. Once the permit has been signed by administration, a copy of the permit will be forwarded to the Town finance department to invoice the Monument Company
7. The Town requires 48 (forty-eight) business hour notice from the Monument Company to perform the approved work at the Cemetery
8. For monument and memorial tablet installations, the Town will mark out the corners of the foundation measurements approved on the permit with stakes and/or orange surveyors paint. The foundation will be marked to center the monument or memorial tablet on the specified location

SPECIFIC MEMORIAL REGULATIONS

The following section contains detailed information on sized and dimensions of monuments, memorial tablets and niche cover as regulated by the *Canmore Cemetery bylaw*.

Monument and Foundation Information

Monuments are of an upright type that general come in two designs; upright and pillow type monument.

UPRIGHT TYPE MONUMENTS (No base or foundation shown in pictures)

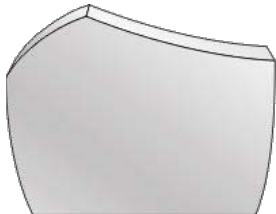

(Irregular shaped)



(Regular shaped)

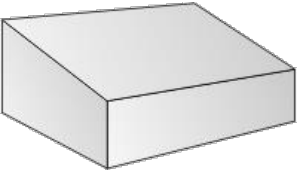

(Pillow- high on back, low on the front)

Terminology Used For Measuring Monument /Memorial Tablets (Figure 3)

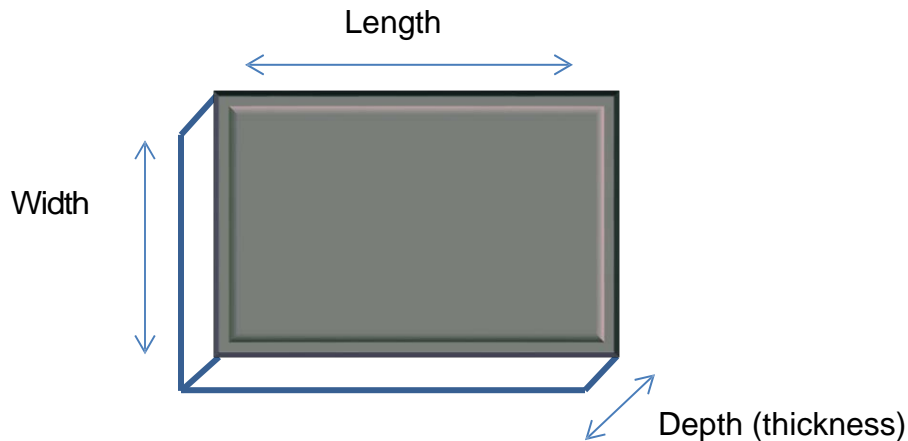

- The length measurement of a monument, memorial tablet or foundation shall mean the measurement as it would face the lot measure from left to right; the width shall mean the measurement as it would face the lot measured from the head of the lot to the foot of the lot; the depth or thickness shall mean the height from top to bottom. **(see Figure 3).**
- If a memorial tablet is mounted on top of a base, to sit above ground, it shall be considered to be an upright monument.
- All monuments require a base and a foundation on top of the base..
- All concrete foundations, whether pre-cast or poured on site for the erection of monuments, shall be the sole responsibility of the Monument Company.
- All foundations for monuments or memorial tablets shall be confined to the boundaries of the plot being 42" length x 24" width for a single plot and 84" length x 24" width for a double plot.
- Foundations of all monuments shall extend 4" in all directions beyond the bottom base of the monument. Measurements for length, width and depth or thickness may be modified or altered for special monuments subject to approval.
- Anything over 42" in length requires the foundation to include 10mm reinforced steel.

Single Plot Monument Measurements:

- Monuments will have a maximum face area of 6 sq. ft.
- Monument shall not be less than 4' (inch) depth or thickness
- See **Table 1** for a sample of acceptable monument sizes

Table 1 Single Plot Monument Multiple Size Choice Samples

| length x width | square in | square ft. |
|------------------------|------------------|-----------------------|
| 30" length x 18" width | = 540 sq. in | or 3.75 sq. ft. |
| 34" length x 18" width | = 612 sq. in | or 3.25 sq. ft. |
| 40" length x 20" width | = 800 sq. in | or 5.55 sq. ft. |
| 38" length x 22" width | = 836 sq. in | or 5.80 sq. ft. |
| 36" length x 24" width | = 864 sq. in | or 6.00 sq. ft. (max) |

Double Plots Monument Measurements:

- Monuments will have a maximum face area of 12 sq. ft.
- Monuments with a face area of 6 sq. ft. to 12 sq. ft. shall be no less than 6" in depth or thickness
- Subject to approval a monument that exceeds 12 sq. ft. in face area shall be not less than 8" in depth or thickness. The base of a monument shall not exceed 25% of the total height of the monument
- See Table 2 for a sample of acceptable monument sizes

Table 2 Double Plot Monument Multiple Size Choices Samples

| length x width | square in | square ft. |
|------------------------|------------------|-------------------|
| 38" length x 18" width | = 684 sq. in | or 4.75 sq. ft. |
| 40" length x 20" width | = 800 sq. in | or 5.55 sq. ft. |
| 45" length x 20" width | = 900 sq. in | or 6.25 sq. ft. |
| 62" length x 20" width | = 1240 sq. in | or 8.61 sq. ft. |
| 72" length x 20" width | = 1440 sq. in | or 10 sq. ft. |

MEMORIAL TABLET AND FOUNDATION INFORMATION

Memorial Tablet

(Sample with no foundation shown in picture)

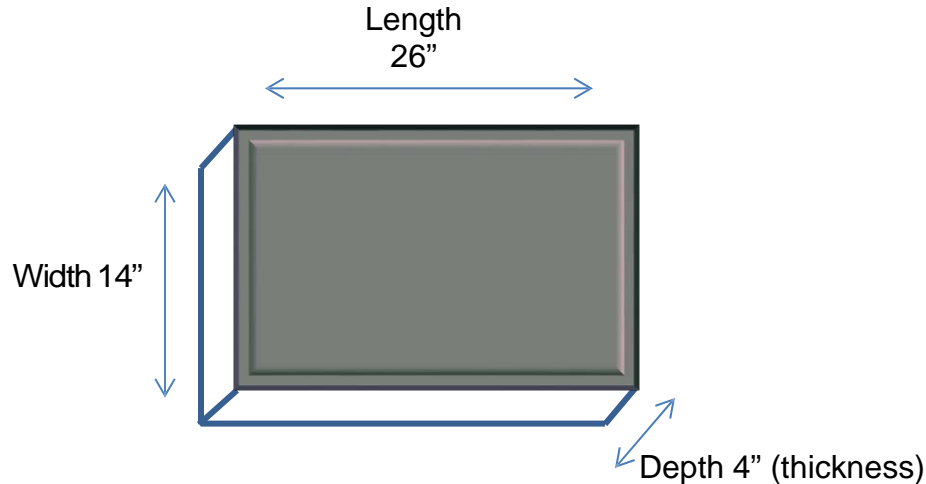

Memorial Table General Information:

- Memorial tablets placed upon a plot shall be granite, marble, stone, or bronze and shall not project above the surface of the ground
- Memorial tablets shall be placed in such a manner as to maintain wherever possible a proper alignment
- The use of bronze is approved for inscription plates when attached to monuments or memorial tablets of natural stone, provided the bronze has been cast from an alloy containing not less than 85% copper and not less than 5% lead
- No other metals are approved
- Bronze inscription plates (ribbons) shall be blind mounted or mounted with tamper proof hardware
- Bronze memorial tablets shall be blind mounted or tamper proof hardware mounted on a concrete base / foundation

Single Plot Memorial Tablet Sizes:

- Shall not exceed 26" length x 14" width and not be less than 4" in depth
- **For multiple burials of 4 (four) or 8 (eight) cremation interments all memorial tablets shall be no larger than 20" length x 12" width**
- shall be properly set in concrete if required according to the specifications.

Double Plot Memorial Tablet Sizes:

- Shall not exceed 36" length x 14 width" (3.5 sq. ft.) and no less than 4" in depth and shall be in place of a monument set at the head of the plot.
- Shall be properly set in concrete according to the specifications.
- Anything over 42" in length must include a concrete foundation with 10mm reinforced steel.

FIELD OF HONOUR MEMORIAL TABLET

- Memorial tablet shall be the Last Post design (grey granite)
- Size must be 20" length x 12" width and 4" depth
- Field of Honour memorial tablets do not need to be set in concrete or have a foundation

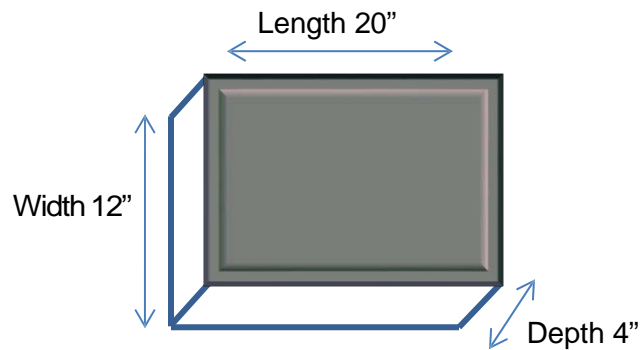

NICHE COVER

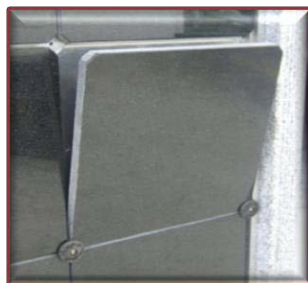

- The Columbarium niche cover is made of black granite and is 11 $\frac{3}{4}$ " length x 11 $\frac{3}{4}$ " width in size.
- Any expenses to having the niche cover engraved shall be covered by the owner.
- The removal or installation of the niche cover must be done by administration.
- The engraving must be done in the font of Modified Roman SR. We recommend all engravings to be handled by our local Monument Company.
- The owner may make arrangements to have the niche cover engraved just before a pre booked interment.



Town of Canmore
 902- 7th Ave
 Canmore, AB T1W 3K1

_____, 2023

Late Labour Fee Contract

The Town of Canmore hereby grants permission for _____ (hereinafter called the Renter) to book an Interment graveside service on _____, 2023 in the Town of Canmore Cemetery subject to the Terms and Conditions of this Agreement contained herein and attached to the Interment Application No. IA _____

Interment services that have not completed their graveside service at the Cemetery by 3:30 p.m. could be subject to Late Labour Fees as agreed upon by this Contract.

Late Labour Fees are invoiced per hour per worker and begin at 4:30 p.m.

Late Labour Fee Rate Applied (check box)

| Late Labour Fees -Weekdays | Labour Fees | Check Box <input checked="" type="checkbox"/> |
|--|--------------------------|--|
| <i>Urn (in ground / Niche)</i> | <i>\$113.00 per hour</i> | |
| <i>Casket**</i> | <i>\$113.00 per hour</i> | |
| Late Labour Fees - Sat / Sun / Statutory Holiday (minimum of 3 hours) | | |
| <i>Urn (in ground / Niche)</i> | <i>\$139.00 per hour</i> | |
| <i>Casket**</i> | <i>\$139.00 per hour</i> | |

** All casket burials require two labourers

I, _____, acknowledge and agree that I have read the terms and conditions to the Late Labor Fee Contract and agree to be bound by them.

RENTER USE BELOW

X: _____

Date: _____

Address _____

OFFICE USE BELOW

X: _____

Date: _____

Employee _____

Title _____

Town of Canmore



CANMORE CEMETERY MASTER FEE SCHEDULE

(effective January 1, 2024 – prices valid until Dec 31, 2024)

Interment Site Fees (Interment Plot/Niche Application)

| Plot (casket & 4 urns, 8 urns, 1/2 plot 4 urns) | Price | GST | Total |
|--|--------------|------------|------------------|
| Single Plot /FOH– Resident | \$ 2,913.00 | \$145.65 | \$3058.65 |
| Single Plot /FOH– Non-resident | \$ 6115.00 | \$305.75 | \$6420.75 |
| Half Single Plot – Resident | \$ 1456.50 | \$72.83 | \$1529.33 |
| Half Single Plot – Non-resident | \$ 3057.50 | \$152.88 | \$3210.38 |
| Columbarium (2 urns) | | | |
| Columbarium (2 urns) | Price | GST | Total |
| Single Niche – Resident | \$ 1888.00 | \$94.40 | \$1982.40 |
| Single Niche – Non-resident | \$ 3830.00 | \$191.50 | \$4021.50 |
| *Please note that costs for plots and niches are for both standard plots and Field of Honour plots upon permission from Canmore Legion. Plots and niches for indigents (social services) will not include GST. | | | |
| Other | | | |
| Other | Price | GST | Total |
| Transfer of Plot/Niche Certificate | \$76.00 | \$3.80 | \$79.80 |
| Columbarium Niche Door Replacement | \$353.00 | \$17.65 | \$370.65 |

Interment Fees (Interment Application Required)

| Interment Type | Price | GST | Total |
|---|--------------|------------|---------------------|
| Casket Interment Summer | \$ 1452.00 | \$ 72.60 | \$ 1524.60 |
| Casket Interment Winter | \$ 2312.00 | \$115.60 | \$ 2427.60 |
| Casket Disinterment Summer/Winter | invoice cost | 5% | invoice cost |
| In-Ground Single Urn @ 2ft- Summer | | | |
| In-Ground Single Urn @ 2ft- Summer | \$ 1080.00 | \$54.00 | \$ 1134.00 |
| In-Ground Single Urn @ 2ft- Winter | \$ 1410.00 | \$70.50 | \$ 1480.50 |
| In-Ground Single Urn @ 4ft- Summer | | | |
| In-Ground Single Urn @ 4ft- Summer | \$ 1474.00 | \$73.70 | \$ 1547.70 |
| In-Ground Single Urn @ 4ft- Winter | | | |
| In-Ground Single Urn @ 4ft- Winter | \$ 2033.00 | \$101.65 | \$ 2134.65 |

| | | | |
|--|--------------|------------|------------------|
| In-Ground Two Urn @ 4ft- Summer Stacked (ex position 1 & 5) | \$ 1540.00 | \$77.00 | \$1617.00 |
| In-Ground Two Urn @ 4ft- Winter Stacked (ex position 1 & 5) | \$ 2097.00 | \$104.85 | \$2201.85 |
| In-Ground Two Urn @ 4ft- Summer Side x Side (ex position 1 & 2) | \$ 1750.00 | \$87.50 | \$1837.50 |
| In-Ground Two Urn @ 4ft- Winter Side x Side (ex position 1 & 2) | \$ 2465.00 | \$123.25 | \$2588.25 |
| In-Ground Two Urn @ 2ft- Summer Side x Side (ex position 5 & 6) | \$ 1498.00 | \$74.90 | \$1572.90 |
| In-Ground Two Urn @ 2ft- Winter Side x Side (ex position 5 & 6) | \$ 2157.00 | \$107.85 | \$2264.85 |
| | | | |
| Columbarium Niche- Single Urn | \$224.00 | \$11.20 | \$235.20 |
| Columbarium Niche- Two Urns | \$288.00 | \$14.40 | \$302.40 |
| | | | |
| Other Interment Fees | Price | GST | Total |
| After Hours Labour -Weekday (per hour, per person, after 4:30 PM) | \$113.00 | \$5.65 | \$118.65 |
| Weekend/Statutory Holiday Labour (per hour, per person, <i>minimum 3 hours</i>) | \$139.00 | \$6.95 | \$145.95 |

Monument Fees (Monument Erection Permit Required)

| Permit | Price | Locate Fee | GST | Total |
|---------------------------------------|----------|------------|--------|-----------------|
| Monument Erecting Permit | \$164.00 | Included | \$8.20 | \$172.20 |
| Monument Removal/ Engraving Permit | \$75.00 | NA | \$3.75 | \$78.75 |
| Niche Cover Erecting Permit | \$76.00 | NA | \$3.80 | \$79.80 |

Weekend & Statutory Holiday Labour Fees

Interment services held on a Sat / Sun or a Statutory Holiday are subject to Weekend & Statutory Holiday Labour Fees (in addition to Interment Fees for each burial type).

| Weekend & Statutory Holiday | Labour Fees |
|---|---|
| Casket** / Urn dig or backfill / niche opening and closing (charges per hour per person / minimum of 3 hours) | Minimum for 3 hrs for one staff: \$ 417.00 + GST |

** All casket burials require two laborers

Late Labor Fees- Weekdays/Weekends & Statutory Holiday

Interment services that have not completed their graveside service at the Cemetery by 3:30 p.m. could be subject to Late Labour Fees. Late Labor Fees are calculated per hour and per labourer and begin after 4:30 p.m.

| Late Labour Fees -Weekdays | Labour Fees |
|--|---|
| Casket** / Urn dig or backfill / niche opening and closing (charges per hour per person) | For one staff, per hour: \$ 113.00 + GST |

** All casket burials require two laborers

Disinterment Fees

Disinterment Fees are on an as requested basis. Fees vary depending on the burial type, location in the Cemetery and the year of Interment. The Town will contract a backhoe and operator. Town employees will work with the backhoe operator to prepare for the disinterment. Contact the Town of Canmore Parks Department for an estimate.

The Funeral Director supplies the remainder of the labour and equipment to remove and relocate. Customers must contact a Funeral Director to obtain information about fees and the necessary Disinterment permits.

For more information, contact the Parks/Cemetery Department at cemetery@canmore.ca