

## Required Documents

The following documents are required for a complete application. Missing documentation may result in delays in approval or a rejection of an application due to insufficient information. **All plans and documents listed below must be submitted through the online portal.**

- Application fee (**Note:** you will be notified via email of outstanding fees with payment details)
- Letter of authorization from the property owner authorizing an agent to act on their behalf for the proposed business (**Note:** This is not required if the property owner is the applicant).
- Current copy of Certificate(s) of Title (issued not more than 30 days from the application date)
- Make and model of the fireplace
- CSA, ULC or WHI approval number for the fireplace

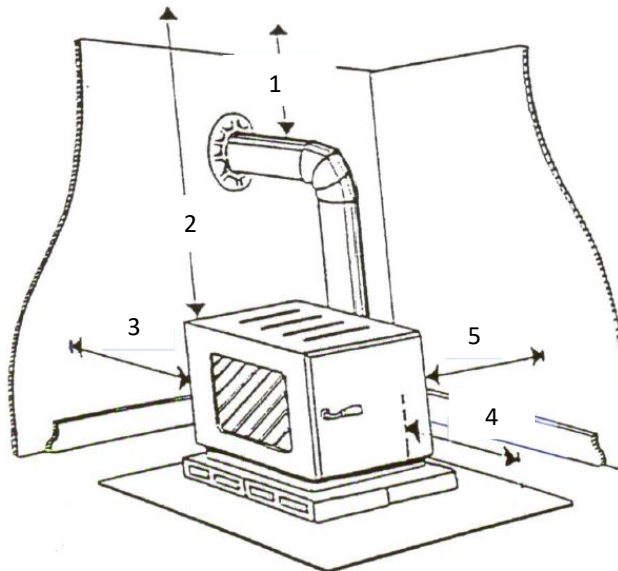

### Required Documents *(cont'd)*

- Distances (scaled in metric) for the following:
  - Top of flue to ceiling (1)
  - Top of stove to ceiling (2)
  - Side of stove to adjacent walls (3 & 4)
  - Rear of stove to adjacent wall (5)

### Advisory Notes

Should your property be located outside the Ten-Minute Emergency Response Map, alterations to your construction design may be necessary. Please visit the [Property Information Viewer webpage](#) to view this map. (Note: you will need to view the Property Information Viewer and check off "Building Code Ten Minute Response Time" to view this information).